

Assembly and Operation Manual



800w – 4.8kw



<http://www.cyclonewindgenerators.com>

All content in this publication is subject to change without notice to prior or future recipients. We reserve the right to make changes to the Cyclone and any related components without notice or updating this manual in a timely manner. Check our website for any posted updates, product warnings or special offers.

Copyright 2009 Cyclone International

Index

Page 2:	Index
Page 3-4:	Introduction
Page 5-6:	Safety
Page 7:	WARNINGS and permits
Page 8:	Tools needed for installation
Page 9-11:	Installation tips
Page 12-26:	Assembly instructions
Page 27-30:	Battery Bank: requirements and connection information
Page 30:	Overview of Cyclone and components
Page 31-32:	Steps to connect your finished Cyclone to the batteries
Page 33:	Recommended Maximum wind speeds for the Cyclone
Page 34-36:	Correct output wire sizing (Line Voltage drop tables)
Page 37:	Finding the correct location to install your Cyclone
Page 38:	Lubrication / Maintenance
Page 39:	Troubleshooting guide
Page 40:	Frequently asked questions
Page 41-44:	Warranty

Contact:

Cyclone Wind Generators

1420 Dolly Varden Way,

Qualicum Beach,

British Columbia,

Canada, V9K2V1

1-250-738-0309

sales@cyclonewindgenerators.com

<http://www.cyclonewindgenerators.com>

Introduction

“Thank you for purchasing a Cyclone wind generator”.

As the new owner of a Cyclone wind generator you will be able to produce your own energy from the wind.

We strongly recommend that a professional install your Cyclone wind generator.

Models 800w -1.6kw:

- *Can* be installed by non-professional installers.

We recommend some aptitude of the use of tools and basic safety knowledge. It is also advised that the installer also have some knowledge of electrical codes and procedures to prevent injury and component damage. If you do not have this knowledge; please avoid the installation process or get assistance from people who do. The results of poor installation could be injury, damage, or failed performance of the Cyclone.

Models 3.2 - 4.8kw:

-Should not be installed by novice installers.

Because of the weight and dimensions it is not a novice item, it is a professional item. The other factor is the current outputs are high on these models and there can be a real danger of shock or death if not installed properly. Warranty may not be honoured if the unit is not professionally installed.

Cable Twist power transfer design:

All Cyclones are cable twist.

Cable twist is now the main method used to transfer power by all large-scale commercial wind generators worldwide. These generators can produce many megawatts per hour; this method is the safest and most reliable for power transfer.

Cable twist is:

A direct connection from the generator output wire to the output wire that travels down the tower to the wind generator controller. The output wire used in the tower is a multi-strand copper supple rubber coated wire that is very flexible.

Firstly there is a 30% increase in output as the output wires are a solid connection which = no loss.

Secondly it is now known that wind generators usually travel a path of 180 degrees or less at any given time on their mounted tower.

So it is unlikely that there would be one full 360-degree twist into any output wire that travels down a tower. Even if there was, in a length of 7 – 38m the twist is almost unnoticeable in that length and does not effect any portion of the wind generators safety or performance.

In fact it increases the safety and performance as the wind generator remains in contact with its controller, which prevents a ‘run away’ wind generator.

Slip rings:

Most other small-scale wind generators on the market are ‘slip ring power transfer’.

Slip rings use mounted metallic rings and spring-loaded metallic contacts, which touch the rings to transfer power from the generator to the output wire, which travels down the tower. This ‘old’ technology was designed as it was believed that a wind generator would turn 360 degrees on its tower many times daily which is untrue. Slip rings are 30% less efficient and are prone to failure and repairs. Once any ‘leg’ of the slip ring assembly fails the wind generator loses its output and the controller is not able to control the wind generator. (Slip ring use in good for wind generators on boats)

Since these assemblies use many small sized low cost parts to transfer the power the chances of failure is always present and the inconvenience and expense to the owner to constantly monitor and repair the slip ring assemblies is ridiculous in light of the new technology that is in use now.

Cyclone wind generators are heavy and can cause serious injury or even death if mishandled.

Please read the whole manual carefully as many important facts are listed in it for the installation and maintenance of your new Cyclone wind generator.

It is very important to note most damage and faulty wind generator behaviour occurs by improper installation methods, installation tools and components.

If you are having a problem with your installation please contact the company who sold you the Cyclone wind generator for their assistance.

All requirements in this ‘assembly and operations manual’ for the Cyclone wind generator are for safety / performance. We do allow some variation such as increasing battery size, increasing output power wire size, using towers designed for LARGER wind generators as long as there is at least 0.5m distances from the tower or guy wires from the blades of the Cyclone wind generator.

Again if there is any doubt, or safety concerns about the methods or materials you are using then get a second opinion.

In most cases you will only have one chance to do the installation correctly.



Safety

It is VERY IMPORTANT to follow all safety suggestions throughout this assembly manual. We cannot be held responsible for any injury or claims of damage to persons or property by the use or misuse of this product or associated parts.

We have used diligence to illustrate that this product has the potential to be dangerous, as it is a machine, which creates electrical power, this machine is erected above the ground, on a tower, and the machine has moving blades that have high rpm's. Purchasing and using this product is for power production, not leisure. It is assumed that any persons or companies who plan to operate this product to make power also will use diligence to make sure its operation is safe and legal.

It is recommended to perform all tasks during assembly and installation using proper safety tools and wearing proper safety protection.

Each Cyclone wind generator produces electricity (volts) and current (amps).
The Cyclone wind generators are all 3 phase AC.
The voltages range from 12VAC to 380VAC.
This current is changed to VDC in the Cyclone controller – separate.

It is crucial that all electrical connections are secure using approved electrical connectors and connection methods, and that all electrical codes are followed to prevent bodily injury or fatal injury. This is also important to prevent damage to the Cyclone wind generator or other components / devices in your energy system.

Lifting the Cyclone wind generator is not an easy task. If you are using one of our tower kits or other brand of tower the risk of dropping the Cyclone wind generator is present at all times when lifting it into its final upright position or lowering it for service.

Always remember anything can happen and even the most “seasoned” professional installers sometimes experience “freak” accidents from failed lifting tools, or sudden adverse weather conditions. Tools that are operating perfectly before the lift can sometimes fail during the lift and there is no way to prevent damage or injury once the tower and Cyclone starts to fall. So diligent safety planning and utmost caution is advised.

Never raise or lower any tower with a Cyclone on it in high winds or in slippery conditions. Many times what is a normal procedure can turn into an accident causing injury or death. The other results of a tower drop is causing damage to the Cyclone, the tower, any tools or surrounding objects / property adjacent to the tower and Cyclone.

This is probably the most dangerous single moment during the installation and it is advised that only people directly involved in lifting the Cyclone wind generator be in the vicinity of the tower and Cyclone wind generator to avoid unnecessary injury or accidental fatal injury to spectators or bystanders.

It is crucial that all towers used with the Cyclone are regularly maintained; this is the number one reason for wind generator failure! Guy wires stretch, guy wire clevises become loose, soil becomes unsettled, anchors become loose; wind causes play /slack in all parts of the tower. We recommend monthly inspection and adjustments if needed.

NEVER replace the nuts provided by the factory with nylon lock nuts!!!
NEVER try to maintain the Cyclone at any time while using a ladder.
Always perform all work, maintenance or repairs with the Cyclone lowered to the ground and fully out of service with all disconnects to batteries etc disconnected.
NEVER use sharp objects to probe, poke or enter any electrical enclosure or junction box while the Cyclone is operating or not operating, current can be present at all times in some enclosures.
NEVER try to stop the Cyclone with a rope or similar tool. Speeding blades can cause bodily injury or death.
NEVER try to stop the Cyclone blades by hand or while using gloves. Speeding blades can cause bodily injury or death.
NEVER get within 10' (3m) of any moving wind generator blades. Speeding blades can cause bodily injury or death.
NEVER try to climb, scale or ascend to the top of any tower. Risk of falling, risk of injury or death from electrical components, and risk of injury from moving parts.
NEVER try to free the Cyclone by hand or using rope if it is not moving (disabled) on the tower. Risk of falling, risk of injury or death from electrical components, and risk of injury from moving parts. Perform all work by lowering the tower and Cyclone to the ground.
NEVER use worn, frayed or multiple pieces of wire to carry the power of the Cyclone to the Cyclone controller, shock hazard is risk and death is also a risk.
NEVER install a Cyclone in an enclosure, pasture, fenced area with animals where the animals could eat /chew the power wire or make the tower fall over.
<p>NEVER</p> <ul style="list-style-type: none"> - Install the Cyclone in a playground - Beside or at a school or frequented children's area - Children are curious and playful and any installation in these areas is just plain negligent and asking for trouble. <p>It would be considered socially shocking and neglectful to leave any Un-attended operating machinery in an area occupied by children. A wind generator is a machine and should be treated like one.</p>

WARNINGS and Permits

The installation of wind generators may be forbidden or regulated in some countries or the smaller geographical areas within countries such as provinces, states, counties, zones, or municipalities.

It is the purchaser's responsibility to make sure that all rules are followed and all permits and by-laws are abided by. We cannot be held responsible.

Due to the nature of this product, we are obligated at this time to make serious warnings for the following:

Serious risk of ELECTRICAL shock or DEATH from this product.

Serious risk of bodily INJURY in association to the operation and maintenance of this product.

Serious risk of property damage as the result of operations of this product.

Moving parts and heavy machinery risk of INJURY.

Heavy objects overhead, risk to FALLING objects.

High speed moving parts, risk of INJURY or DEATH.

Serious risk or ELECTRICAL shock to surrounding areas adjacent to this product.

Serious risk of LIGHTNING contact during storms from the tower and in the vicinity of the tower and this product.

Although the PROPER use of this product should not imply that it is unsafe to operate. It must be remembered though at all times this product does have the potential to be dangerous 24/7.

The purchaser / user must exercise a foremost responsibility to ensure that the product is placed in a location that has low traffic (pedestrian and vehicular). And installed in a manner in which the risk of injury to persons, animals and damage to surrounding property is minimal. Fenced compounds are good if uncertain.

Wind generator use around the world is a popular method for power production. Our product has the same potential as other brands of wind generators for injury, death, or property damage, and the warnings above should and do apply to all similar products.

Tools needed for installation

A tool kit is provided in each packing box that the Cyclone wind generator is delivered in.

The nuts and bolts used on the Cyclone are metric.

Depending on the size of the Cyclone you have purchased, the tower you are using etc, the additional tools can vary from a winch to commercial cranes.

Some suggested items to have on hand:

Level	Used to get the tower (plumb) perfectly vertical.
Small Hammer	Used to tap bolts into place move stubborn items, care should be used to NOT distort threads on bolts, bend items on the wind generator kit etc.
Vice grips	Used for holding and clamping.
Grease	All weather light grease, lithium is good.
Cement	General Portland type based cement used on anchors, tower bases etc. On large projects it is recommended to use ready-mix cement made commercially and delivered to your site ready to pour.
Shovel / Backhoe/ Excavator	Digging anchor holes, base plate hole, the size of tool needed here depends on the size and scale of the installation you are undertaking.
Electrical items	Electrical tape, marretts, electrical wire strippers, multi-meter AC/DC, “Red” Robertson screw driver,
Tape measure	Up to 25’ and 100’
Miscellaneous	Assorted wrenches large and small, wire cutters, cement trowel, sandpaper
High temperature Lock-tight	This is a bolt and nut cement that makes all nut and bolt, and bolt to body connections secure. This liquid forms a bond (that can be removed in the future), to prevent the bolts from becoming loose over time. Doing this while assembling the Cyclone will ensure you do not have to lower the tower and Cyclone often to make adjustments such as replacing bolts that have fallen out or to tighten any nuts or bolts. Usually you cannot spot any bolts that have fallen out from the ground so this gives you piece of mind and also ensures the unit will not fail because of a loose nut/bolt.



Installation tips

Please read all tips thoroughly. They cover a variety of topics and usually contain important information about installation safety and general operations.

In order to get your warranty you must read this section and all sections of the manual fully before operating your Cyclone wind generator.

Your signature is required for the warranty and also a declaration that you have indeed read the manual. This declaration is law binding.

Many contractors and homeowners now use poles purchased and sometimes installed by utility companies.

This practice is accepted by us as suitable mounting for our wind generators as the poles are normally certified and exceed the the strength needed to mount a wind generator.

We also recommend this as the utility contractors can install and maintain your wind generator.

If your using a tower with guy wires, it is advised to install the tower and raise and lower it in advance before installing the Cyclone wind generator. If any adjustments need to be made, such as guy wire tightened, getting the tower “plumb” (perfectly vertically level). Making sure you have enough power – output wire to go from the generator through the tower to reach the battery enclosure. This “practice lift” will help you spot and give you time to correct any problems in advance. Sometimes it is necessary to repeat this step until the tower is secure and the guy wires (if used on the tower you are using) are also secure and all fastening devices are double-checked.

Caution the lift will be completely different once the Cyclone is installed onto the tower, as its weight now will create a real danger to the lifters of the tower and any by-standers.

The height of the tower you use should be clear of any obstructions such as trees buildings etc. It is advised that the Cyclone have at least 20’ or 7m of height, above the tallest object in its vicinity. It should have a full 360 degrees of clear wind access, for at least 100m of its towers circumference. If the Cyclone is installed in an area where it does not have a clear path in all directions that Cyclone will be operating in what is called “turbulent winds”. (Installing a taller tower is a solution).

These winds are destructive in many ways, they cause gusts /shears, and create an environment of turbulence that makes the Cyclone shake, vibrate and causes premature failures. The other results are the Cyclone stalling in one spot (direction facing East, West, South or North) with the blades not turning. This is when the wind cannot reach the Cyclone as it is obstructed by trees, buildings etc. No wind = no power.

It is advised if using a till up tower or even if you are using a crane lifted tower to have a “rest” (tall saw horse or other strong support apparatus to lift / support the tower top off the ground while you install the Cyclone onto the tower top, and to support it before the lift into the final upright position). This makes installation a less rushed process and prevents blade damage. You may require having many “rests” to prevent the tower from bending in the middle or other centre

<p>sections while the Cyclone is being installed. The tower is in its most vulnerable position when laying slightly erect at one end, this is the towers weakest moment and support should be placed under the tower at any point that looks like it is bending or sagging.</p>
<p>Bending the tower is wrong and if at any time any actual bends (visual defects) take place never raise that tower again until it is properly repaired and checked by a professional. Once the tower is bent or “kinked” it is likely the tower will fail at the “kinked” or bent section at some point in the future or immediately when trying to raise it depending on the severity of the damage it has received.</p>
<p>Never rest the Cyclone and / or Cyclone attached to the tower at any time on its blades, the blades will crack or break as they are thin fibreglass and <u>are not</u> designed to support any weight. This will void the warranty.</p>
<p>It is advised to assemble the Cyclone on a secure stand or flat surface such as the ground, back of a service vehicle, table etc before installing the Cyclone onto the tower.</p>
<p>It is advised at this time to check the fit of all items, and make sure all nuts and bolts are tightened securely. The use of a high grade heat resistant “lock-tite” on the nuts and bolts is strongly suggested to prevent them from becoming loose and falling off during normal operation. Remember the winds will be very brutal and strong at times and if bolts should fall out failure /damage /injury will be the result. This also will void the warranty.</p>
<p>Never permanently install the blades on the hub and onto the generator shaft until the Cyclone is mounted securely on the tower. This will prevent any accidental blade damage while the unit is positioned into place.</p>
<p>At this time it is best to make sure the Cyclone can turn easily on the tower top (stub). If there is any tightness and the Cyclone nacelle (metal body) cannot turn freely this is the time to make adjustments to the nylon bushings found inserted into the metal body, which the tower top is inserted. This procedure is covered in detail in the “adjustments” section of this manual.</p>
<p>It is also advised to check that the tail fin also can move freely and that there is some lubrication on the tail fin shaft. The lubrication should be “all weather” light grease, and only a small amount should be applied, as a large amount will actually cause the tail to stick in one position in freezing cold temperatures.</p>
<p>This is also the time to make sure all electrical connections are secure. Make sure the Cyclone can turn freely on the tower top left to right and full 360 degrees with no restrictions. Also check at that time that the electric output wire that travels from the Cyclone and down the inside of the tower, is also moving freely with no obstructions and that there is no interference with the Cyclone wind generator, or tower as it hangs down.</p>

This is important to prevent the Cyclone from becoming stuck facing one direction and not turning when pushed by wind. It is also to avoid failures in the electrical output power wire causing the Cyclone to become “free wheeling” (out of control) and also to prevent any type of electrical shock or electrical injury or death on high output models.

DO NOT use a rigid type of wire as the output wire. This wire will become brittle and break quickly. This is dangerous as the tower could become electrified and anyone who comes in contact with the tower could receive a shock or fatal shock. The output wire should be supple and move freely in all directions. A soft flexible rubber encased wire similar to electric welding wire is best. This wire should be UV protected and have a multi-strand copper wire inside, single strand copper wire will fail. Single strand wire cannot move in all directions when the Cyclone turns on the tower top and will become brittle and break. You will have no power output at that time and the Cyclone will “freewheel” (spinning out of control), this will cause many failures including generator, and blade failures, which are not covered by warranty if this happens. The Cyclone is designed to operate “under load” which means the unit is always working. When the blades turn, the Cyclone controller is controlling the Cyclone. Once the output wire is broken the controller can no longer control the Cyclone and damage is the result.

Once all the above functions are performed properly it is time to install the hub and blades and nose cone. Install the hub and make sure the nut, which holds the hub onto the tapered shaft has “lock-tite” thread cement applied to the threads to prevent this main nut from becoming loose and the hub and blades falling off the Cyclone. Again the results are property loss and possible injury / death.

The same applies again to the attachment of the blades. Make sure the bolts and nuts are tight and use “lock-tite” on every bolt. Please pay careful attention to the blade installation instruction covered in the assembly portion of this manual as there are IMPORTANT steps that must be followed exactly, that if not followed will cause unbalanced blades which will make the Cyclone shake, reduce output, cause noise eventually and also cause pre-mature failure in the blades and all related parts including the generator. So this one area it is very, very important to pay close attention to the instructions in this manual.

Assembly

Before we start the process of assembly; please note the following important information:

All bolts and nuts are already installed by the factory into the correct parts and locations on the parts that they should be located in.
This is done to save time and to eliminate the possibility of incorrect placement of nuts and bolts. This practice assists in correct Cyclone assembly.
It is advised that you only remove any nuts and /or bolts for assembly when you attach one specific part at one time. This will eliminate all possible chance of installing the nuts and bolts into incorrect locations, or in an incorrect manner.

Figure 1:

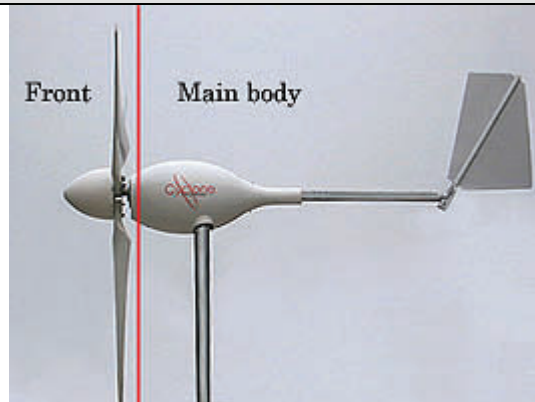

Picture Figure # 1: is the completed 800w - 1.6kw Cyclone wind generator.

You will notice the assembled Cyclone has a red line drawn through it.
We have divided the Cyclone wind generator into 2 areas for assembly instructions.
These areas are labelled as the “**Front**” and the “**Main body**”.
The following pages will go into detail for both areas for all model sizes of Cyclone wind generators from 800w – 4.8kw.

The “Front” Section

The parts below are located in the front section of the 800w-1.6kw Cyclone.

Part numbers for the 800w-1.6kw front section:

Part No.	Quantity	Part Description	Checklist
001	1	Hot dipped galvanized steel hub	<input type="checkbox"/>
002	1	Hub backing plate	<input type="checkbox"/>
003	3	Fibreglass gel coated blades	<input type="checkbox"/>
004	1	Keyway nut-lock and nut	<input type="checkbox"/>
005	1	Fibreglass gel coat nose cone	<input type="checkbox"/>

Figure 2:

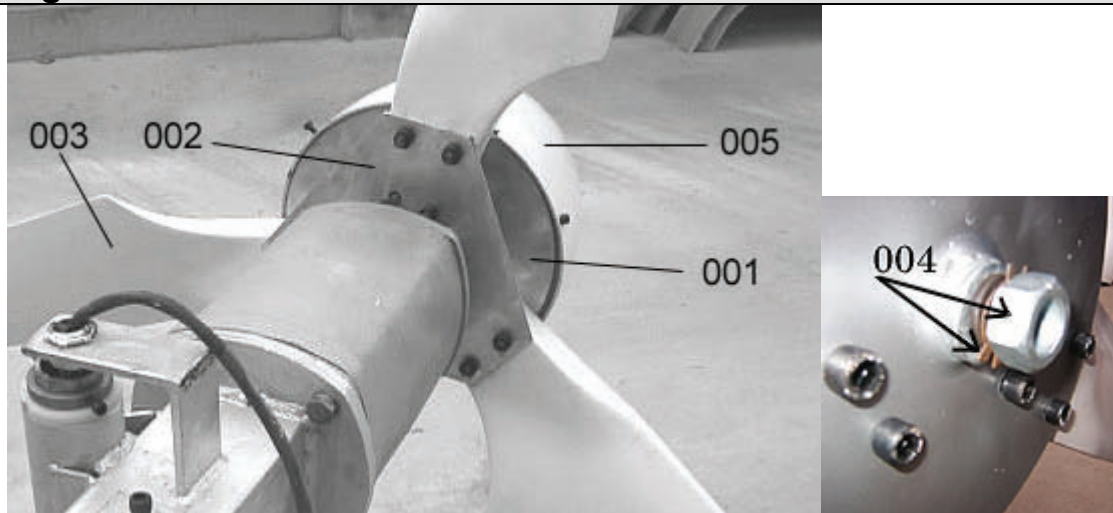

All models 800w – 3.2kw use the same style mounting method for the blades and hubs.

The nuts are positioned on the back of the hub #001 “as shown” the bolts are inserted through the front of the hub, through the blade #003 and the backing plate #002. When you open your wooden Cyclone shipping box you will notice the bolts and nuts are already attached to the hub they are installed at this time correctly please make sure they are placed back in the same position after you install the wind generator blades

Please pay attention to the direction the blades are facing in figure #2.

Hub and blade assembly

STEP ONE - NOTE:







Please pre-read [all](#) blade and hub instructions fully before you assemble the blades and hub.

NOTES:

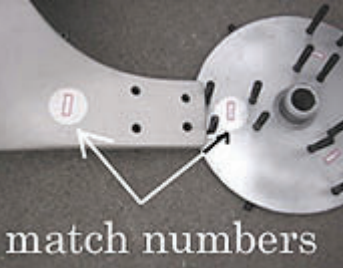
It is advised to use a high heat automotive type “lock-tite” thread cement on all bolt threads to ensure the nuts and bolts do not come loose during normal operation. Apply the “lock-tite” and make all bolt and nut connections finger tight through the first process in the picture table below. Move onto the next step without delay to make final adjustments to the blade position for balance and then make the final tightening of all nuts and bolts on the blade and hub area of the “Front” Section.

DO NOT leave the lock-tite on the threads for long periods before tightening! Check the “lock-tite instructions” carefully to avoid lock-tite hardening before you finish.

The following pictures show proper installation of the Cyclone blades (props) and hub.

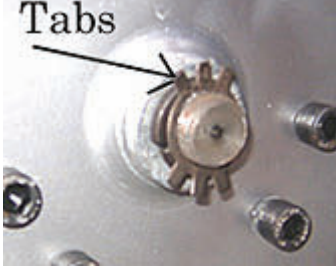
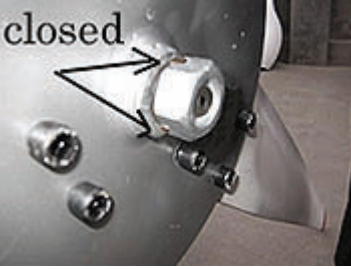
		
<p>Install bolts through front of hub</p>	<p>Match numbers, hub - blades</p>	<p>Install backing plate. Match numbers with blades</p>
		
<p>Add lock washers and nuts tighten by fingers only</p>	<p>Hub with all bolts, blades and backing plate installed</p>	<p>Install hub and blades onto generator shaft – see above</p>
		
<p>View from generator (back view of hub and blades)</p>	<p>Close-up photo of keyway lock for nut, once nut is tight in final position</p>	<p>Fold the 3 tabs from each side around the nut, to keep nut from moving.</p>

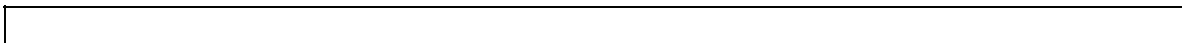

The parts below are located in the front section of the 4.8kw Cyclone.

Part numbers for the 4.8kw front section:

Parts No.	Quantity	Parts Description	Checklist
001-3	1	Hot dipped galvanized heavy built steel hub	<input type="checkbox"/>
003-3	3	Fibreglass gel coated aerodynamic blades	<input type="checkbox"/>
004-3	1	Lock washer and nut	<input type="checkbox"/>
005-3	1	Nose cone	<input type="checkbox"/>

The 4.8kw hub and blades (shown below) the process is much the same as the process for the 800w-3.2kw. The main difference is the hub style and the attachment of the 4.8kw blades. Again we stress to use “lock-tite on all threads of bolts.

Photos - 4.8kw hub and blades:

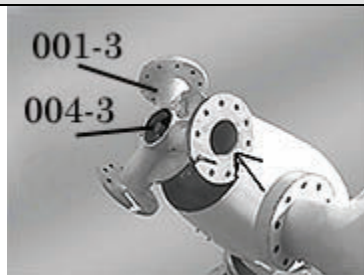

This photo above shows the hub before the blades are attached

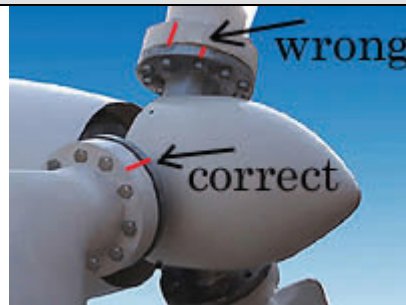

Match these marks to make sure each blade has the same pitch

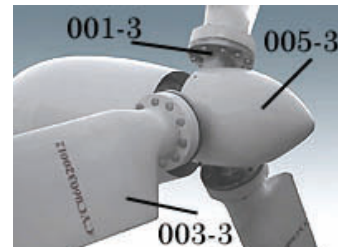

The 4.8kw should look like this when completed

Before you attach the blades to the hub, make sure you match the “position marks” on the hub to the blades. Also match and place the correct blade with the matching hub spindle. Bolts and nuts should not be fully tightened with tools until equal spacing of “A, B, and C” are performed.

SEE – figure # 3 below.

The process is the same for all sizes 800w-4.8kw. Once you have the measurement of “ A, B, and C” the same distance as in figure #3. Then it is Ok to fully tighten the nuts and bolts.

**Figure#3
Making sure the blades are evenly spaced**

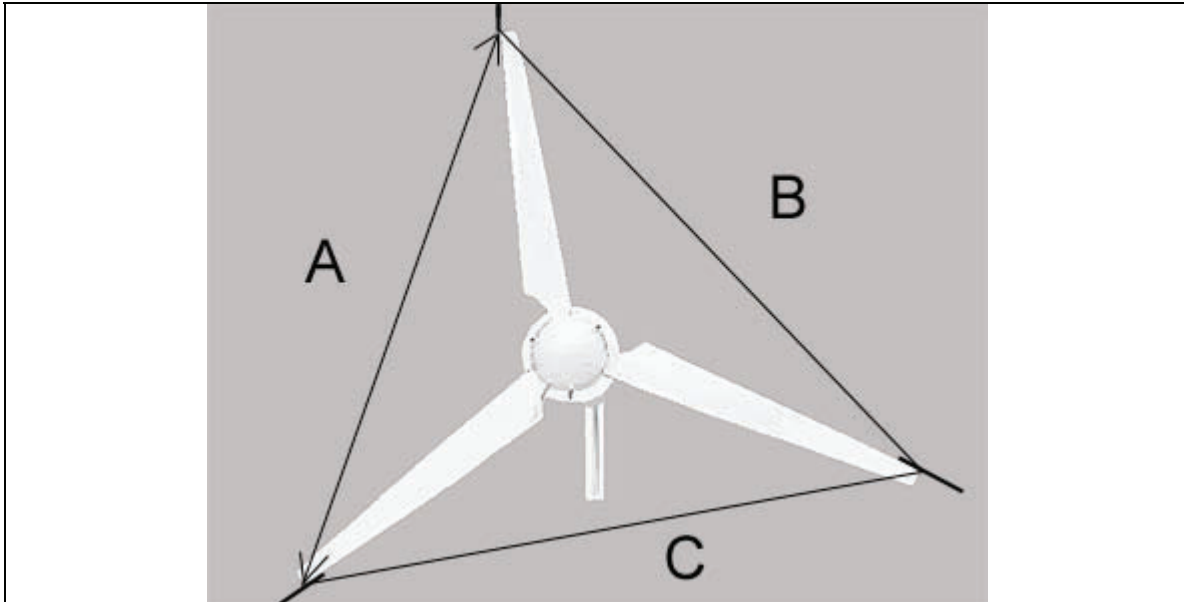

Measure from the same location at the end of each blade to get a true measurement.

See “A” above. Do the same with “B” and “C” until all measurements are the same.

Summary:

Before the blades are permanently secured to the hub, it is wise to first make each nut and bolt tight by fingers only, not by tools. You must first measure from the exact same locations shown in this photo figure#3.

If you find that one distance is smaller or greater than the other you must move the blades slightly until you have all 3 sides of “A”, “B” and “C” equal distance apart.

If you skip the important steps above, the blades will not be balanced.

The result is the side with the smallest measurement will have too much weight and this will cause pre-mature wear on the generator bearings, cause shaking of the Cyclone when it is operating, this may occur at slow or high speeds or all the time when it operates. This can also cause other failures in the generator and also cause other parts on the body and tail to become loose over time and to fail.

The shaking also reduces your power output.

It is best to make sure this step is performed accurately before you raise the tower, as it is very easy to do so at that time.

Once you have achieved the same distance in “A”, “B” and “C”. You can then make the final tightening of the nuts and bolts with tools. It is advised to add “lock-tite” bolt cement to all nuts and bolts when first making them “finger tight” to avoid them from coming loose during normal operation. If the bolts come loose or fall out it could cause serious injury or death, property damage, or make the Cyclone fail.

It is also advised to make sure that during the final tightening that the blades did not move and that all 3 sides of “A”, “B” and “C” are the same distance apart.

So please re-check all the measurements.

If the blades have moved during final tightening repeat all steps above until it is done correctly.

NEVER replace the factory nuts with nylon lock nuts!!!

Final step to complete the front is to mount the nose cone.

Nose Cone Installation:

Remove all 3 nose cone bolts from the side of hub, place the nose cone on the hub and insert all 3 bolts back into the holes they came from. Again the use of “lock-tite” thread cement is recommended. Only screw the bolts in half way, so there are threads still showing. This will allow you to adjust the nose cone to make sure it is straight and that all bolts can be reinserted. Once this is done tighten all bolts. **DO NOT** over-tighten the bolts the result will be the fibreglass cracks or breaks. The nose cones primary purpose is to split the air and allow it to pass the body with the least amount of resistance. This improves the Cyclones performance and output.



Remove all 3 bolts from the thin outside edge of the hub



Place the cone on the hub on and install all 3 bolts half tight - do not tighten yet



Once the cone is centred and all bolts are in correctly finger tight then you can final tighten

Operation without the nose cone actually gives reduced power outputs.

The “Main body” section

Assembly of the body section

Read this whole section carefully as the instructions apply to 800 watt – 4.8kw Cyclone models. The first photos are of 800 watt - 1.6kw models, examples of the 3.2 and 4.8kw models are shown later in this same section. All structure design is the same.

Please see the picture “**figure # 4**” below for location of all parts contained in the body section.

Parts of the 800 watt – 1.6kw body section:

Parts No.	Quantity	Parts Description	Checklist
005	1	3 phase AC generator	<input type="checkbox"/>
006	1	Adjustable body cover bracket	<input type="checkbox"/>
007	1	Hot dipped galvanized heavy steel body	<input type="checkbox"/>
008	1	Tower locking cap	<input type="checkbox"/>
009	1	Cable grip	<input type="checkbox"/>
010	3	Tail arm supports	<input type="checkbox"/>
011	1	Tail arm	<input type="checkbox"/>
012	1	Tower stub	<input type="checkbox"/>
013	1	Grease fitting	<input type="checkbox"/>
014	1	Cable clamp	<input type="checkbox"/>

Figure # 4

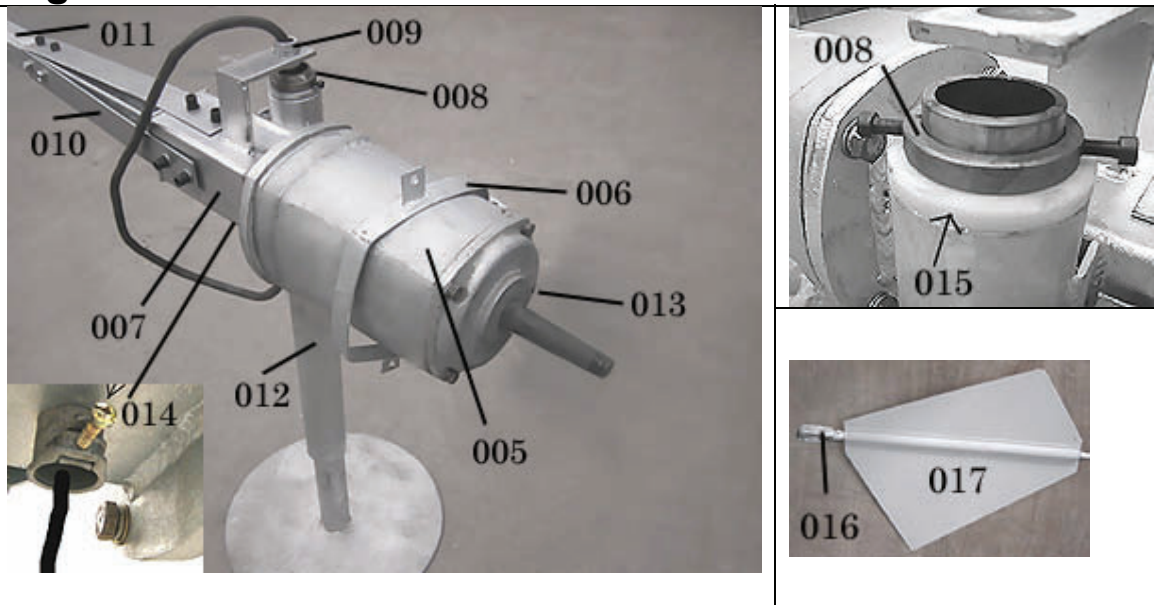

Looking at the first picture in the picture table below you will see the hot dipped galvanized metal bodies come shipped with all bolts installed in the proper location when you receive your Cyclone. Viewing the picture below you can see how / where to add the 3 tail arm supports / braces. Again please use “lock-tite” on all bolts and nuts.















Picture of body as it looks from



Remove bolts as needed to



Body without bolts

<p>the delivery box all bolts are installed</p>	<p>start assembly we suggest to only remove bolts on the area you work on</p>	
 <p>The tail arm attaches to the end of the metal body by 4 bolts</p>	 <p>NOTE: make sure the tail arm is in upward position before you attach to the body. This picture shows the correct position.</p>	 <p>Insert all 4 bolts and make sure you use “lock-tite” on all bolts Do final tighten after all bolts are in finger tight use - Allen wrench provided</p>
 <p>Add all 3 tail supports (1-top and 2 sides) to the body and the tail arm - use “lock-tite” on all bolts</p>	 <p>This side picture shows all supports attached to the body correctly</p>	 <p>This top picture shows all supports attached to the body correctly</p>
 <p>This side view of the tail arm shows proper placement of the tail arm braces on the tail arm All bolt and nuts should be fully tightened. NOTE: use “lock-tite” on all bolts</p>	 <p>Side photo / 3.2kw and 4.8kw shows correct placement of tail arm supports. Placement is 1-top, 1-bottom and 1-side. NOTE: use “lock-tite” on all bolts</p>	 <p>Top view of tail support for 3.2kw and 4.8kw. The tail arm is attached with 6 bolts. Again insert all bolts before tightening. NOTE: use “lock-tite” on all bolts</p>
		 <p>nylon bushing</p>

<p>Picture is without shaft collar (tower clamp which prevents the Cyclone from moving off the tower during operation). NOTE: this step is not for the 3.2kw or 4.8kw Cyclone as those models the tower flange bolts directly to the tower.</p>	<p>This pictures shows the clamp being installed onto the tower stub.</p>	<p>This picture shows the tower clamp in its final position. NOTE: do not make the clamp tight against the nylon bushing, make sure the Cyclone body can turn fully 360 degrees with no friction suggested space 2mm</p>
--	---	---

3.2 and 4.8kw body parts

In the table below and also in figure # 5 you will see the part codes for the 2 and 3kw body parts

Parts No.	Quantity	Parts Description	Checklist
005-3	1	3 phase AC generator	<input type="checkbox"/>
006-3	1	Adjustable body cover bracket	<input type="checkbox"/>
007-3	1	Hot dipped galvanized heavy duty steel body	<input type="checkbox"/>
009	1	Cable grip (same on all models 300w-3kw)	<input type="checkbox"/>
010-3	3	Tail arm supports	<input type="checkbox"/>
011-3	1	Tail arm	<input type="checkbox"/>
012-3	1	Tower stub	<input type="checkbox"/>
013	1	Grease fitting (same on all models 300w-3kw)	<input type="checkbox"/>
014	1	Cable clamp (same on all models 300w-3kw)	<input type="checkbox"/>
015-3	2	Bushings top and bottom for tower mounting	<input type="checkbox"/>
016-3	1	Tail fin mount and assembly	<input type="checkbox"/>
017-3	1	Tail fin	<input type="checkbox"/>

Figure # 5

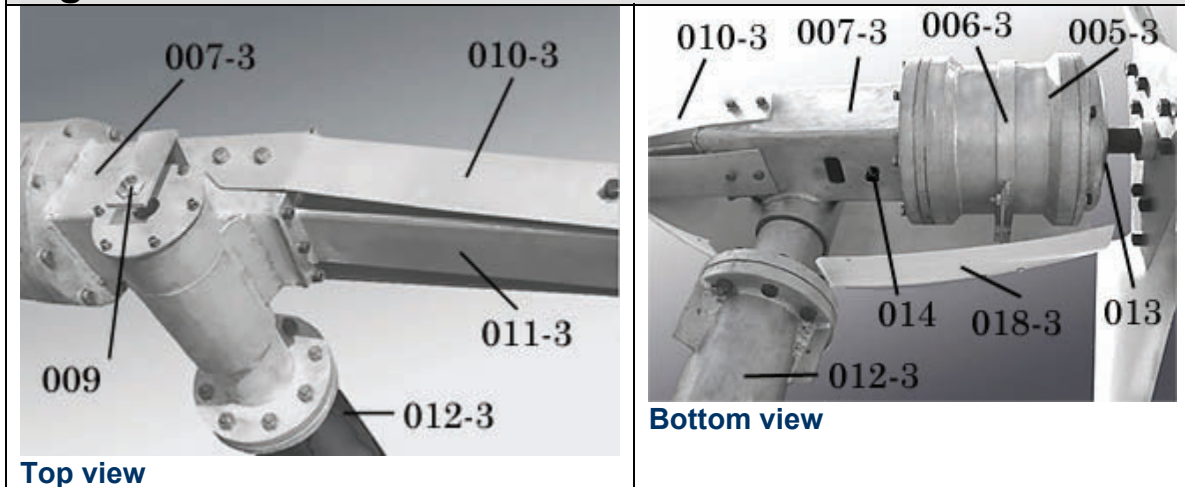

Please note:

1. There is no part # "008" on the 3.2 - 4.8kw models as the tower stub is bolted directly to the tower preventing the Cyclone from becoming un-attached.
2. Parts # 016-3 and # 017-3 (tail fin and tail fin mount assembly) look the same as all other models in the above sections.

Installing the tail fin:



Pictured above is the tail fin, the fin itself is powder coated, the mounting hardware is hot dipped galvanized



The tail arm mount should look like the picture above, place the tail fin mount inside the tail arm and align all holes.



Once you have aligned all holes insert the 2 bolts that hold the tail fin to the tail arm.



NOTE: Before applying the nuts to the bolts add “lock-tite” to all threads on the bolts.



At this time the fin and mount should look like this. Fully tighten all nuts and bolts.



Tail complete. The tail fin should look like this.

Installation of output wire

This step is done at the same time as the placing of the body onto the tower.

CAUTION:

We advise all electrical connections be performed by a certified electrician or under the supervision of qualified electrical personal.

It is best to make sure you have enough wire to reach the junction box and also to make a safe connection with plenty of slack in the output wire so it is not tight over the body and in its seats in the cable grip and cable clamp.

Correct placement of the power output wire from the Cyclone junction box into the tower.

Figure 5:

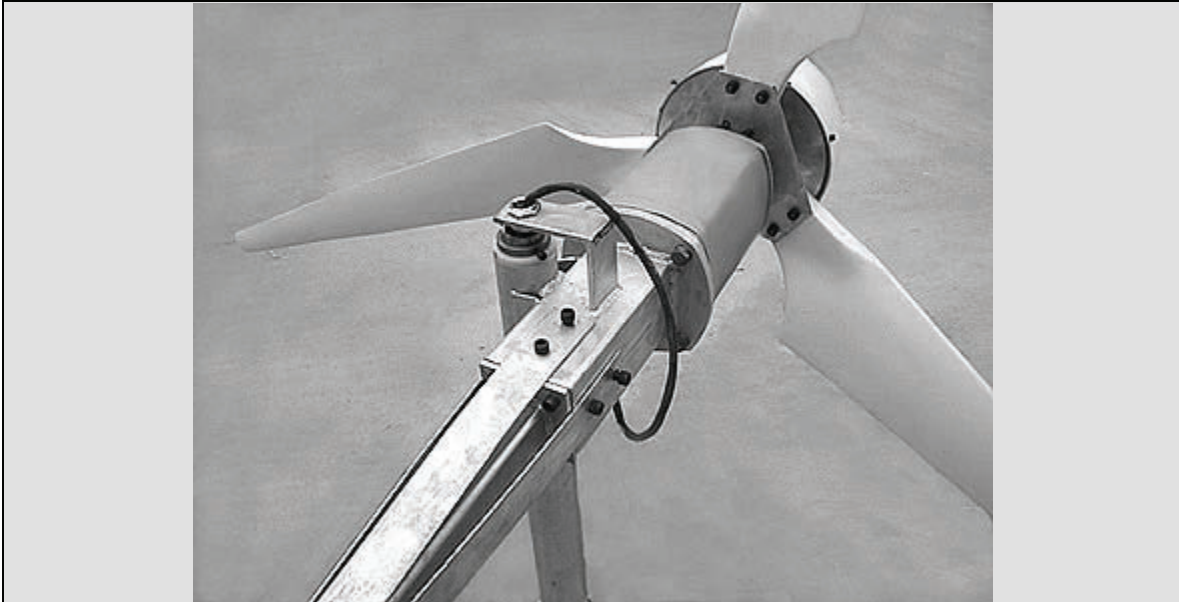

Your Cyclone should look like this.

Note: the output wire enters the cable grip then into the tower.

Tip: leave enough slack in the wire to allow for movement.

The Cyclone blades should also look like the above picture when looking at the Cyclone in the same position.

Figure 6:

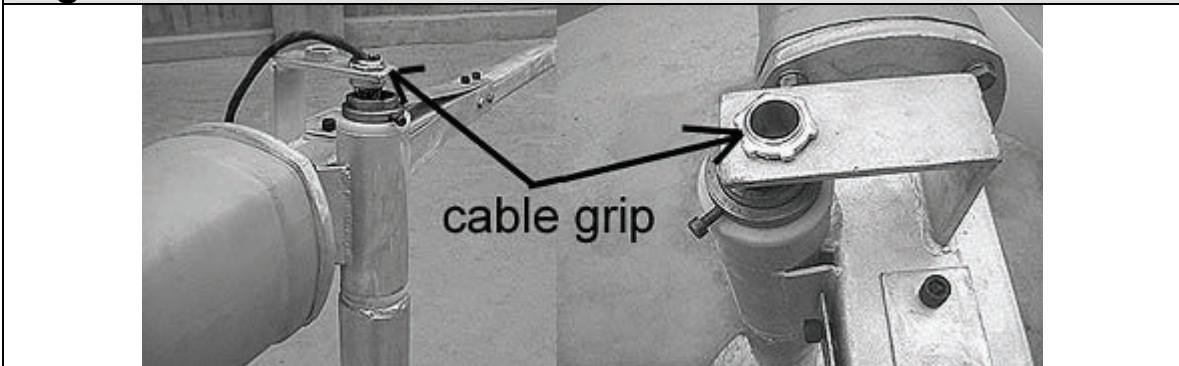

The cable grip is shown above.

The figure # 6 Picture above shows the correct placement of the output wire in the cable grip and tower.

CAUTION:

Make sure when installing the power output wire that it is free moving inside the tower when the Cyclone moves on left or right on the tower.

Figure 7:

The cable grip, junction box and cable clamp are the same on all models.
Installation for the power wire is the same on all models 800w – 4.8kw.

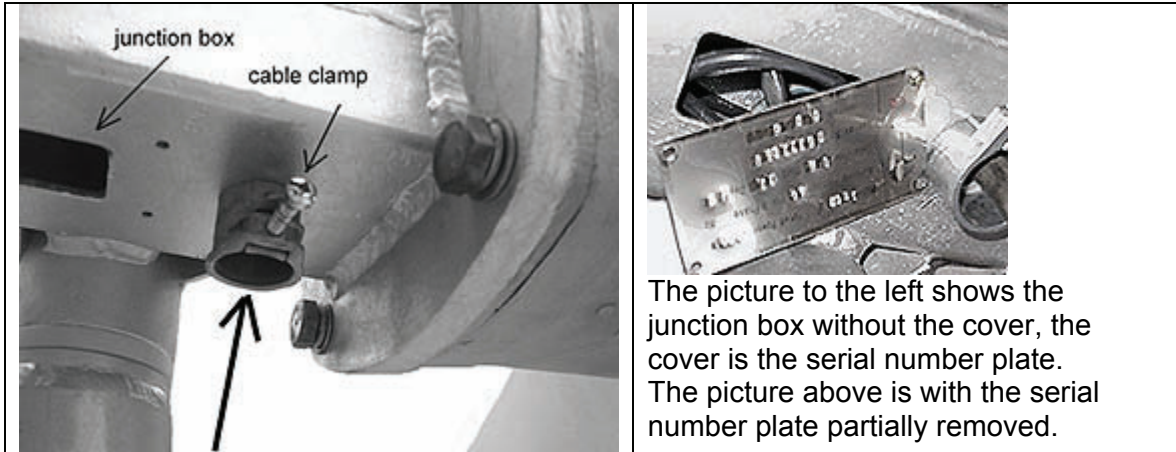

The picture to the left shows the junction box without the cover, the cover is the serial number plate. The picture above is with the serial number plate partially removed.

Figure # 7 above: The output cable from the tower enters the body of the Cyclone through the cable clamp.

Connections should be made with Marrettes or other secure code approved methods and sealed with rubber tape or heat shrink tubing.

<p>Models 800w-4.8kw Photo of junction box opening All connections must be made using code approved connectors</p>	<p>Example of Marrette connectors These are code approved for electrical connections</p>	<p>Other code approved connectors and heat shrink materials</p>
<p>Pull both sets of output wires (from generator and also from wire that goes down the tower) out of the junction box opening so connections can be made without mistakes. Shown is rubber tape over Marrettes this is the minimum grade of connector allowed.</p>	<p>Once the connection is made and is waterproofed place the connection back into the junction box, there is ample room for the wires inside the junction box as shown above.</p>	<p>Place the serial number plate back over the junction box opening and secure with the provided screws.</p>

Adding the Cyclone body cover:

It is advised during this process to again use 'lock tite' on the bolts and nuts provided.

NOTE: It is also advised to make all bolts and nuts finger tight until all nuts and bolts are in place for the initial installation of the mounting of side M (see –below). Make sure that side 'N' fits and that the cover is centred around the generator at the front and fits the tail arm at the back before making the final tightening.

Figure # 8 below:

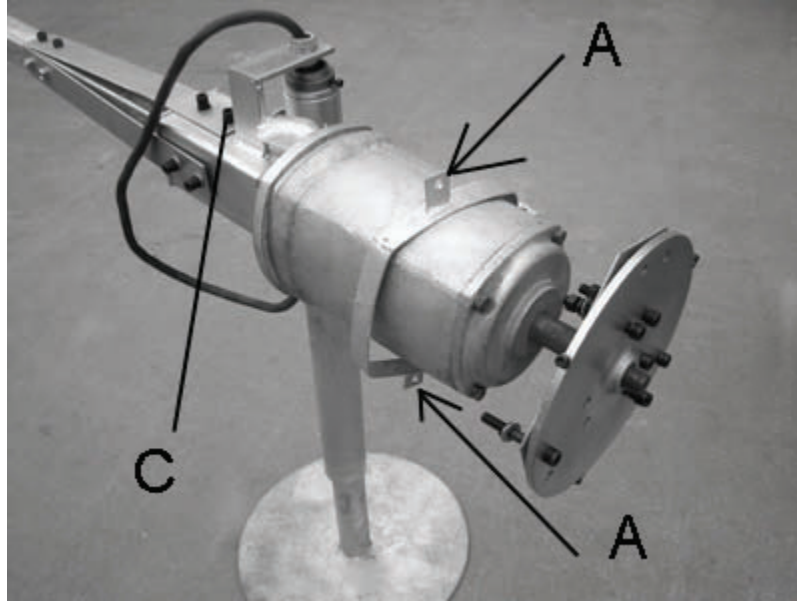

Adjustable body cover mounting bracket

In the picture to the left and the picture above A, B, and C show the main mounting areas for the fibreglass body cover.

'A' and 'C' hold the cover in place. 'B' is the adjustment in the mounting bracket

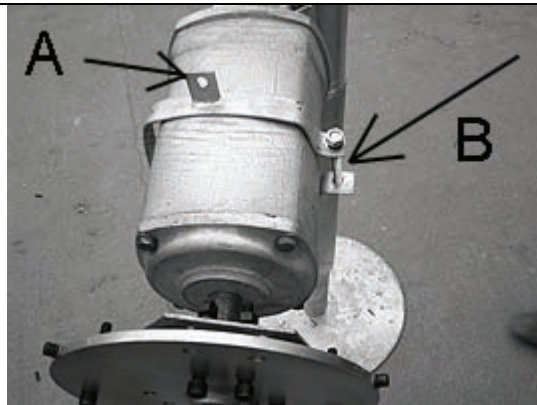

The tower side (M) of the fibreglass body cover has mounting tabs and bolts and nuts attached when you receive your Cyclone



To mount tab 'C' you must remove or delay placing the bolt that holds the tail arm support. This is another good reason to pre-read the instructions before you begin assembly. Once in place reinsert this bolt finger tight until final placement is made.



The picture above (and enlargement to the right) shows the 'A' mount clearly



Place the bolt and nut into tab 'A' at this time.



Make this bolt finger tight until final placement is decided.

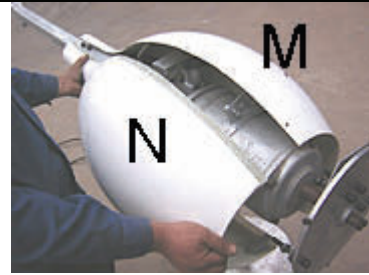

Tower side 'M' is now mounted before making the final tighten check that side 'N' fits and that the cover is centred on the generator front and that other areas fit correctly.



Once it is determined that the fit is correct finish installing all other nuts and bolts using lock-tite to ensure there are no lost bolts and nuts during operation which could lead to accidents or bodily injury or breakage of any Cyclone parts.



Battery bank requirements for Cyclone:

The most common mistake is to install a battery bank, which is too small to handle the power you are producing.

When it comes to batteries larger is always better.

Comparison:

If wind generator output power were compared to numbers of people, it is easier to move 50 people on a bus then it is to move 50 people in a small car. In this case the batteries are being considered as the bus and car.

Many times the use of a small battery bank can cause the Cyclone to act in a manner that would appear there is a defect in the wind generator. This could be rough operation, stopping for no reason, noises from the generator etc. Many times once the undersized battery bank is full and the Cyclone is producing its rated output or more, the controller will continuously dump the Cyclone's output power and also search for an opportunity to resume charging.

Some controller models have an electronic stop feature where the controller will try to stop or slow down the Cyclone if the batteries are full. The end result is the batteries; the controller and the Cyclone are under stress while they try to cope with trying to charge a full undersized battery bank. All this causes pre-mature wear and stress on the entire system and could reduce the lifespan of all your components. Also your generating power from wind experience is also not a pleasant one.

Now if a larger battery bank is used, besides the direct benefit of having extra power available, it allows the Cyclone extra capacity to charge batteries and not waste your energy production in your dump load. The Cyclone and all other components will operate smoothly and this will extend the life of all components in the system. This is more important when you receive a constant wind strong enough to have full output for a long duration of time such as 24hrs or perhaps 1-week non-stop production. (This is not normal every day outputs but it is normal for everyone to experience this at some times throughout the year). If for instance a 1500AH battery bank is used and the Cyclone is producing 20 amps output the almost full batteries are able to absorb this charge with no problem, as the charge is small in comparison to the total capacity of the batteries themselves. But if you are using a 400AH battery bank 20 amps output can be too much if the batteries are close to fully charged. Thus the output power must be diverted or disposed of.

Example:

In 24 hrs of 20 amps production you could produce 480AH this is a greater amount then a 400AH battery bank. It is easy to see how hard it is on the components to dispose of this power. With a large battery bank of 1500AH, 24 hrs of 20 amps production (480AH) would be less then 30% of the battery banks total amp hour capacity. So it is less stressful for all components as the produced energy amount is little compared to the battery bank size of 1500AH. The estimate below is generous for estimating battery bank AH.

A good safe fast estimate is this: "24hrs full output (AH) x 3 = battery AH".

So when you think of batteries bigger is better.

NEVER USE automotive batteries always use deep cycle batteries only!

Please follow the table below for the correct battery bank size for your

Cyclone. Please use the correct size AH to match your voltage.			
No.	Model of Cyclone	Suggested Battery Bank Minimum AH (amp hours) @ Maximum 20 hour discharge	
1.	600w	1000 AH @ 24 or 48vdc	1500 AH @ 12vdc
2.	800w	1200 AH @ 24 or 48vdc	2000 AH @ 12vdc
3.	1.6kw	1500 AH @ 24 or 48vdc	2500 AH @ 12vdc
4.	2.3kw	1500-2000 AH @ 24 or 48vdc	
5.	3.2kw	2000 AH @ 48vdc	
6.	4.8kw	2000-3000 AH @ 48vdc	

Examples of battery configurations:

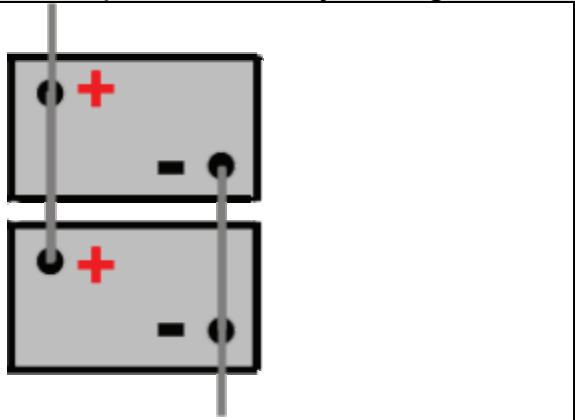
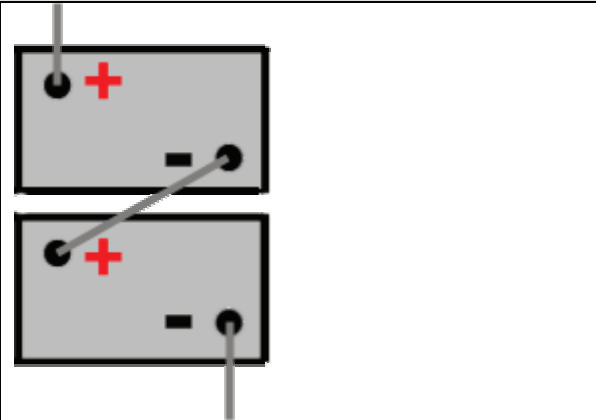
																	
<p>The picture above shows batteries wired in parallel</p>	<p>The picture above shows batteries wired in series</p>																
<p>The main function for this is to boost the AH of the batteries you are using. By connecting the batteries together positive into positive and negative into negative.</p> <p>NOTE: The voltage stays the same.</p>	<p>The main function of this configuration is to boost the voltage of the batteries you are using. By connecting the batteries together positive into negative.</p> <p>NOTE: The AH stays the same.</p>																
<p>Example:</p>	<p>Example:</p>																
<table border="1"> <thead> <tr> <th>Battery AH before</th> <th>Battery AH after</th> </tr> </thead> <tbody> <tr> <td>100 AH</td> <td>200AH</td> </tr> <tr> <td>1000AH</td> <td>2000AH</td> </tr> <tr> <td>1500AH</td> <td>3000AH</td> </tr> </tbody> </table>	Battery AH before	Battery AH after	100 AH	200AH	1000AH	2000AH	1500AH	3000AH	<table border="1"> <thead> <tr> <th>Battery volts before</th> <th>Battery volts after</th> </tr> </thead> <tbody> <tr> <td>2 volts</td> <td>4 volts</td> </tr> <tr> <td>6 volts</td> <td>12 volts</td> </tr> <tr> <td>12 volts</td> <td>24 volts</td> </tr> </tbody> </table>	Battery volts before	Battery volts after	2 volts	4 volts	6 volts	12 volts	12 volts	24 volts
Battery AH before	Battery AH after																
100 AH	200AH																
1000AH	2000AH																
1500AH	3000AH																
Battery volts before	Battery volts after																
2 volts	4 volts																
6 volts	12 volts																
12 volts	24 volts																

EXTREME CAUTION must be used when working with batteries. Shock, acid burns or death is a real danger!

Batteries wired in both parallel and series to increase both voltage and AH.

The picture below illustrates the use of both parallel and series to increase both the voltage of the batteries you are using and the AH of the batteries you are using. This is normal practice in order to have a battery bank such as 12, 24 or 48 volts from 2 volt, 6 volt or even 12-volt batteries.

Repeat NOTE: NEVER USE Automotive batteries. Automotive batteries have low AH and have thin plates which make them weak and subject to inner plate failures, use can

be dangerous from over charging, explosions / fire can occur.

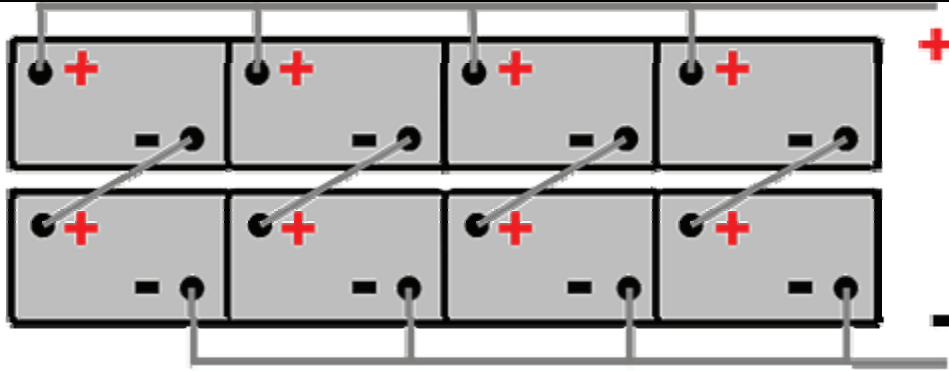

EXAMPLE: If the batteries above were 6 volt batteries with 225 AH each.

The new configured voltage and AH would be: 12 volts / 900AH

If the batteries above were 12 volt batteries with 225 AH each.

The new configured voltage and AH would be: 24 volts / 900AH

Battery Types:

Deep Cycle 12 volt (such as marine batteries etc) **Lowest recommendation**

This type of battery can be found in different shapes and sizes. Such as marine batteries up to 120AH and some sealed batteries, which can have up to 200AH per battery.

We suggest the 200AH sealed if you are in this price category.

For those on a small budget these are a good starter battery for your battery bank.

Good features:

Easy to configure
Not expensive
Less connections

Bad features:

Low capacity
Lightweight, this is not good when considering battery plate strength
Lifetime of 2 - 5 years

Deep Cycle 6 volt (such as golf cart batteries etc) **Medium recommendation**

This type of battery can be found in different shapes and sizes. Such as golf cart 6-volt batteries up to 270AH and the L-16, which can have up to 370AH per battery. They are small and have a higher capacity in AH (amp hours storage) compared to 12-volt batteries.

For those on a medium budget these are a good starter battery for your battery bank.

Good features:

Lightweight to move around.
Can be purchased at many locations
Cost

Bad features:

Low capacity
Lightweight, this is not good when considering battery plate strength
Lifetime of 3 -10 years

Deep Cycle 2 volt (industrial or telecom batteries) **Highest recommendation**

This type of battery can be found in different shapes and sizes. Sometimes forklift batteries are pre-wired and mounted in a steel enclosure, but are 2-volt cells. Telecom or industrial batteries are lead acid; some are AGM (absorbed glass mat). This is a serious long-term battery if cared for properly they can last up to 20+ years. This is the best battery to have for high amp hour battery banks or full time use.

Good features:

High capacity
Long lasting 15 - 20+ years
Durable

Bad features:

Expensive
Heavy
Difficult to move

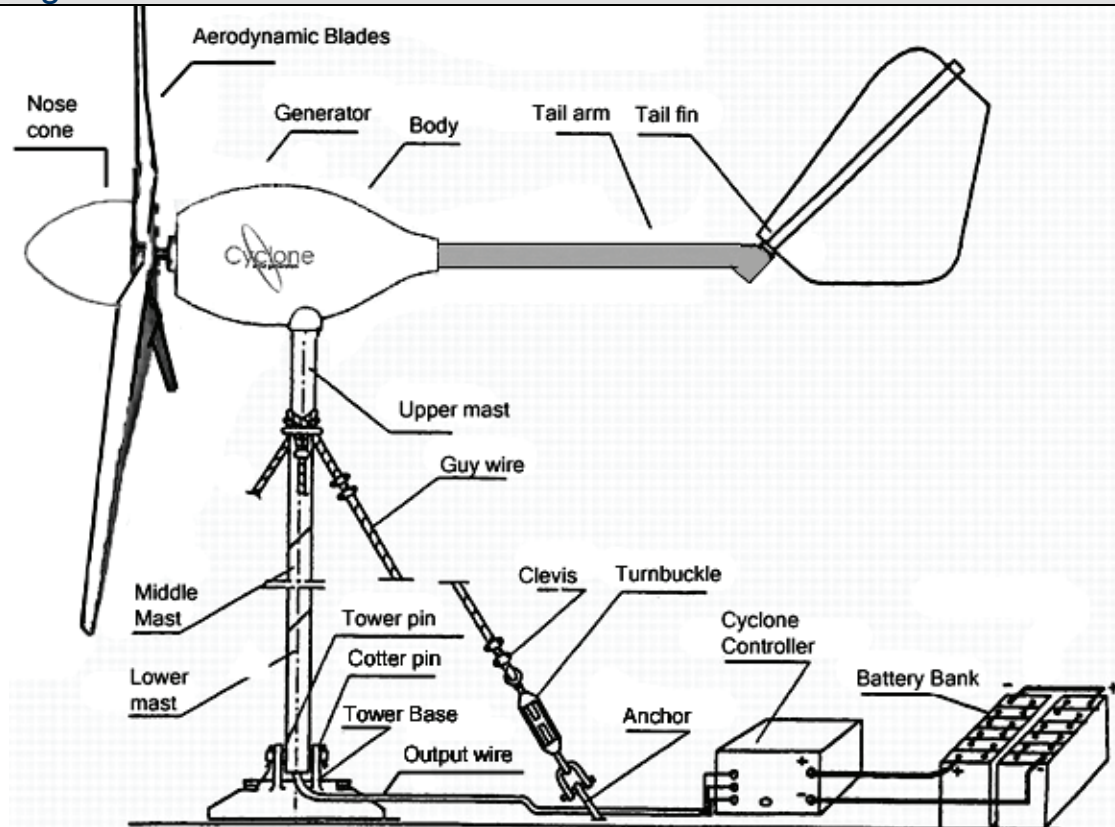
Figure #9

In the diagram above you are able to see an overview of how the Cyclone is installed in relation to the other general parts needed to operate the Cyclone.

The Cyclone is a 3 Phase AC generator and in order to charge batteries the current must be converted into DC by the Cyclone controller.

Other controller functions:

Controls the battery charging voltage, keeps the Cyclone from over charging the batteries by diverting excess power to an external dump load. Keeps the Cyclone working at all times when the wind is present (the Cyclone blades must never spin without the controller/dump load attached to the output wires when mounted for operation).



Steps to connect your Cyclone to batteries:

Step 1:

BEFORE you lift the Cyclone.

Once your Cyclone is completed and is ready to erect to its final position on its tower, it is advised at this time to connect all 3 AC output wires together at the end of the AC output wire in your battery room or at the base of the tower (if possible) to prevent the Cyclone from creating any volts or amps. This also stops the blades from turning. This will prevent anyone who works on the Cyclone at this time from getting shocked from its current.

Step 2: Connecting the controller

It is advised at this time to make sure all connections from the controller to the batteries and dump load are finished. Double-check all connections at this time. Check for battery voltage in the controller with your multimeter.

When connecting:

The controller should be turned off.

The controllers wind generator brake should also be turned ON at this time.

A DUMP LOAD 2 X the capacity of the controller is mandatory and MUST be connected!

Cyclone controllers come standard equipped with a 2X capacity dump load included.

NOTE:

If a fuse is used between the batteries and the controller, make sure it is a minimum of 200amps.

NOTE:

If you are using a controller that is non-Cyclone:

It must be rated for 2- 3X the rated output of the Cyclone you are using. The controller MUST have a dump load.

The dump load must be 2X the capacity of the controller.

IF these rules are not followed and you have not declared this on your warranty, the warranty on the Cyclone will be void.

Step 3:

Raise the Cyclone.

Once the Cyclone is secure in its final position, and all work is done except the final connection of the Cyclone to the controller.

Now it is time to make the final connection.

NOTE:

Since this final connection needs to be done with no controller / electrical protection to the Cyclone wind generator at this time, we advise that the final connection be done when there is **NO WIND**. OR not enough wind to make the Cyclone's blades turn (under 3m/s - 5mph)

At this time you will separate the 3 main AC output wires that come down the tower from the Cyclone generator and make the final connection to the Cyclone controller.

NOTE:

There is no pre-determined order for the 3 "live" output wires to be attached to the 3 input

receptacles on the Cyclone controller.

NOTE:

DO NOT touch these wires at any time to any metal enclosures or other parts of any other components.

Connect the wires to the 3 terminals for the Cyclone 3 phase AC input.

Make sure the connection is secure and the wires cannot come free with gentle steady pull.

Once it is certain the connection is secure.

You may turn on the controller.

You may release the Cyclone wind generator brake. (Turn it off).

Wait for wind to turn the blades of the Cyclone and read any readings in the amp and volts digital meters at this time.

We recommend a certified electrician or a qualified experienced installer perform all connections.

Operation NOTES:

During the first few hours of operation it is advised to watch the Cyclone while it operates and also keep a watchful eye on the controller.

If any problems occur at this time such as vibration of the Cyclone where the Cyclone shakes while the blades turn open the controller enclosure and activate the Cyclone wind generator brake.

Read the troubleshooting guide or contact your dealer for instructions.

If you are worried about any things that don't seem right at this time again contact your dealer.

It is OK to keep the brake activated indefinitely so if it is a holiday or weekend do not panic!

NEVER leave the Cyclone un-attended for long periods of time.

EXAMPLE:

NEVER Leave it connected and operating at your cottage over the winter.

NEVER Leave it connected and operating at your home while you are on holidays.

We are warning at this time that this could lead to many problems, such as failures, injury, fire etc. A wind generator is a machine. You would not leave other machines operating unattended for long periods of time.

Apply the brake and stop power production until you return.

Commercial unattended use in remote locations:

For those who intend to use the Cyclone commercially in remote locations with no supervision for long periods of time, it is advised to talk with a technical representative about your use.

There are ways to plan these situations to have the best results.

Simply installing the Cyclone and walking away in a remote setting is dangerous and we officially do not recommend this use without our consent.

Recommended Maximum Wind speeds

To clarify the wind-speeds for general information purposes and warranty issues.

Damaging Winds: What are they?

Damaging winds are most commonly occur in winds over 30 mph / 12 m/s / 50km. It is impossible for anyone to truly know exactly when they will occur and where they will occur. Damaging winds are winds, which can be strong gusts, wind shears etc. The most difficult area for us when offering warranty is to extend the warranty over 30mph as we do know when tested in a controlled environment of pure wind no-gusts the wind generator blades can handle winds up to 140km/h. But if the blades were to be hit by gusts or shears in a strong windstorm it is only speculation to how strong the gusts can or may be in any given storm and what damage if any will occur. Some storms break trees and hydro poles and leave much damage and it should be expected the wind generator should suffer loss at that time too.

This sounds vague what can we do in real world applications of operating our Cyclone to make sure we do not loose service of our wind generator?

WIND WARNINGS: Gusts (60 km/h +) and potential of damaging winds:

It is common sense to stop operation and power production when these warnings are issued. It is not the steady wind that is damaging it is the wind gust that hits the wind generator at a different angle or directly at the blades when the damage occurs. Please keep in mind these wind warnings are issued for serious reasons. Many times trees etc are heavily damaged during these warnings, and it is impossible for any manufacturer to make a 100% guarantee against any wind damage in these situations.

WARRANTY:

We have tested our wind generator and the wind generator blades and have conclusive results that:

1. **100% warranty** under 16 m/s = 57.6 km/h =35.79 mph if there is damage to the Cyclones blades during 5 years of normal operation.
2. **50% warranty** over 16 m/s – 39m/s if there is damage to the Cyclones blades if there is no storm damage
3. **No warranty** if the Cyclone was operated in a damaging windstorm with weather office warnings to take caution against possible wind damage.

This is why we offer a reasonable approach of urging all customers to protect their investment by stopping production for the short term when there are warnings of possible wind damage during storm warnings so they can enjoy the Cyclone for the long term.

Cyclones can withstand winds up to 39 M/S.

(140 km/h – 87 mph)

Not including damaging winds.

Voltage drop tables: (copper wire)

PLEASE NOTE:

Tables below based on total wire length from the Cyclone generator to the Cyclone controller.

Do not use under sized wire / it will void your warranty.

It is dangerous and illegal to use under sized wire, risk of fire, electric shock / death.

Match wiring sizes with Cyclone model and voltage:

The tables below are for reference only.

For exact wire sizes to be code compliant to electrical codes in your area consult a certified electrician.

The amperage listed for all models is calculated at rated output.

We assume no liability and do not imply at any time that the tables below are code compliant for your area.

-	-	-	-	-	-
NO			YES		

12 volt line loss charts below:

Model: 600 watt 12volt (3 Phase AC, (3 power wires) with a Maximum 5% voltage drop)

The charts below offer maximum distance for the gauge specified, for this model and voltage

Max Amps	Distance Meters	Distance Feet	#10	#8	#6	#4	#2	#1	#1/0	#2/0	#3/0
21.5	11	36	-	-	-	-	-	-	-	-	-
	17	57	-	-	-	-	-	-	-	-	-
	27	90	-	-	-	-	-	-	-	-	-

Model: 800 watt 12volt (3 Phase AC, (3 power wires) with a Maximum 5% voltage drop)

The charts below offer maximum distance for the gauge specified, for this model and voltage

Max Amps	Distance Meters	Distance Feet	#10	#8	#6	#4	#2	#1	#1/0	#2/0	#3/0
36	10	34	-	-	-	-	-	-	-	-	-
	16	54	-	-	-	-	-	-	-	-	-
	26	84	-	-	-	-	-	-	-	-	-

Model: 1.6kw 12volt (3 Phase AC, (3 power wires) with a Maximum 5% voltage drop)

The charts below offer maximum distance for the gauge specified, for this model and voltage

Max Amps	Distance Meters	Distance Feet	#8	#6	#4	#2	#1	#1/0	#2/0	#3/0	#4/0
71	13	42	-	-	-	-	-	-	-	-	-
	16	53	-	-	-	-	-	-	-	-	-
	20	65	-	-	-	-	-	-	-	-	-

24 volt line loss charts below:

MODEL: 600 watt 24volt (3 Phase AC, (3 power wires) with a Maximum 5% voltage drop)

The charts below offer maximum distance for the gauge specified, for this model and voltage

Max Amps	Distance Meters	Distance Feet	#12	#10	#8	#6	#4	#2	#1	#1/0	#2/0
11	17	55									
	27	88	-								
	43	140	-	-							
	68	223	-	-	-						
	107	350	-	-	-	-					

Model: 800 watt 24volt (3 Phase AC, (3 power wires) with a Maximum 5% voltage drop)
 The charts below offer maximum distance for the gauge specified, for this model and voltage

Max Amps	Distance Meters	Distance Feet	#12	#10	#8	#6	#4	#2	#1	#1/0	#2/0
18	16	54	-								
	26	85	-	-							
	41	135	-	-	-						
	65	215	-	-	-	-					
	101	330	-	-	-	-	-				

Model: 1.6kw 24volt (3 Phase AC, (3 power wires) with a Maximum 5% voltage drop)
 The charts below offer maximum distance for the gauge specified, for this model and voltage

Max Amps	Distance Meters	Distance Feet	#14	#12	#10	#8	#6	#4	#2	#1	#1/0
36	13	43	-	-	-						
	21	68	-	-	-	-					
	33	108	-	-	-	-	-				
	51	168	-	-	-	-	-	-			
	63	208	-	-	-	-	-	-	-		
	79	258	-	-	-	-	-	-	-	-	

48 volt line loss charts below:

Model: 600- watt 48volt (3 Phase AC, (3 power wires) with a Maximum 5% voltage drop)
 The charts below offer maximum distance for the gauge specified, for this model and voltage

Max Amps	Distance Meters	Distance Feet	#16	#14	#12	#10	#8	#6	#4	#2	#1
5.5	42	138	-								
	66	218	-	-							
	108	355	-	-	-						
	171	560	-	-	-	-					

Model: 800 watt 48volt (3 Phase AC, (3 power wires) with a Maximum 5% voltage drop)
 The charts below offer maximum distance for the gauge specified, for this model and voltage

Max Amps	Distance Meters	Distance Feet	#14	#12	#10	#8	#6	#4	#2	#1	#1/0
9	26	85									
	40	132	-								
	65	215	-	-							
	105	345	-	-	-						
	165	540	-	-	-	-					

Model: 1.6kw 48volt (3 Phase AC, (3 power wires) with a Maximum 5% voltage drop)
 The charts below offer maximum distance for the gauge specified, for this model and voltage

Max Amps	Distance Meters	Distance Feet	#14	#12	#10	#8	#6	#4	#2	#1	#1/0
18.5	12	41									
	20	65	-								
	32	105	-	-							
	50	165	-	-	-						
	81	265	-	-	-	-					

Model: 3.2kw 48volt (3 Phase AC, (3 power wires) with a Maximum 5% voltage drop)
 The charts below offer maximum distance for the gauge specified, for this model and voltage

Max Amps	Distance Meters	Distance Feet	#12	#10	#8	#6	#4	#2	#1	#1/0	#2/0
37	16	52	-								
	25	83	-	-							
	41	133	-	-	-						
	64	209	-	-	-	-					
	99	325	-	-	-	-	-				

Model: 4.8kw 48volt (3 Phase AC, (3 power wires) with a Maximum 5% voltage drop)
 The charts below offer maximum distance for the gauge specified, for this model and voltage

Max Amps	Distance Meters	Distance Feet	#12	#10	#8	#6	#4	#2	#1	#1/0	#2/0
55.5	17	55	-	-							
	27	88	-	-	-						
	43	140	-	-	-	-					
	66	218	-	-	-	-	-				
	82	270	-	-	-	-	-	-			

120 volt line loss charts below:

Model: 3.2kw 120volt (3 Phase AC, (3 power wires) with a Maximum 5% voltage drop)
 The charts below offer maximum distance for the gauge specified, for this model and voltage

Max Amps	Distance Meters	Distance Feet	#14	#12	#10	#8	#6	#4	#2	#1	#1/0
25	23	77									
	37	121	-								
	59	193	-	-							
	94	307	-	-	-						
	149	490	-	-	-	-					
	235	770	-	-	-	-	-				

Model: 4.8kw 120volt (3 Phase AC, (3 power wires) with a Maximum 5% voltage drop)
 The charts below offer maximum distance for the gauge specified, for this model and voltage

Max Amps	Distance Meters	Distance Feet	#14	#12	#10	#8	#6	#4	#2	#1	#1/0
37.5	16	52									
	25	81	-								
	40	132	-	-							
	63	206	-	-	-						
	101	333	-	-	-	-					
	160	525	-	-	-	-	-				

Finding the correct location to install your Cyclone:

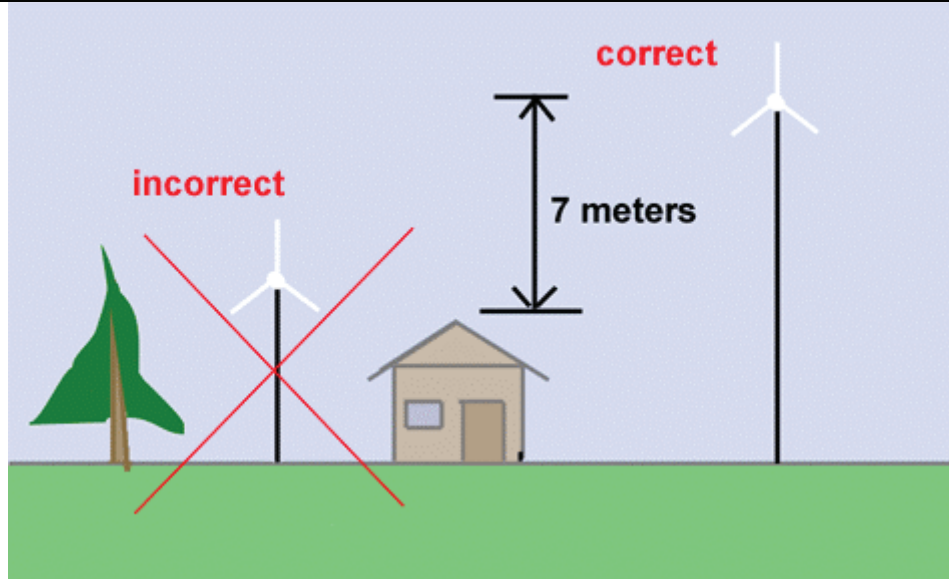

To avoid installing your Cyclone in a turbulent wind situation there are ways to help prevent this by proper location, placement and height of the tower. In the picture above the Cyclone is 7 meters above any buildings or trees, allowing it direct access to clean flowing undisturbed wind.

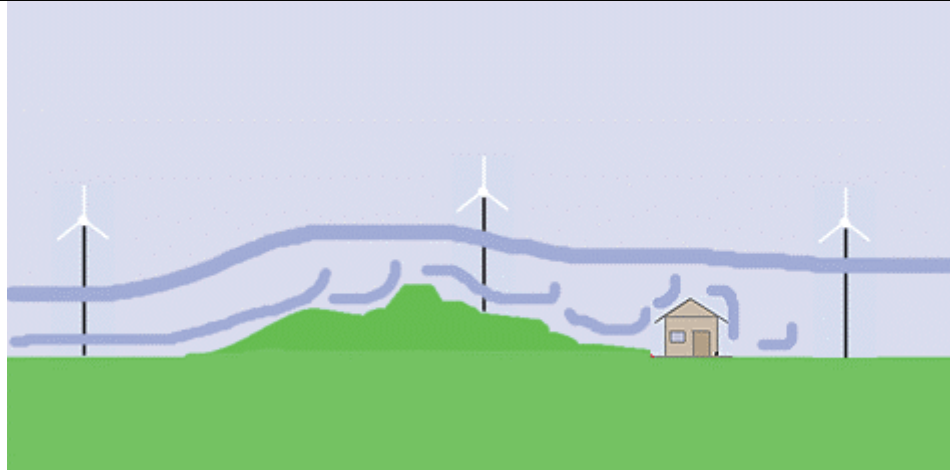

In the picture above there are blue lines, which would indicate, wind if we could see it with our eyes.

The wind flow that is high in the picture and smooth flowing over the landscape closest to the wind generators is good for power production.

The wind close to the ground is turbulent and as it travels over obstacles such as hills buildings trees etc. the wind changes direction into upward and downward directions as well as travelling its normal path.

This turbulent behaviour besides having the potential to be damaging also inhibits the wind generators ability to produce its full output.

The wind generator is working hard to maintain a steady output in conditions that do not offer it steady wind flow. Operation in these winds also shortens the wind generators lifespan.

Lubrication and Maintenance:

“Lubrication and Maintenance” should be performed in the first 1-2 years and in intervals of the same time during its lifespan.

If the Cyclone is working near full capacity in its first year it is advised to perform all maintenance on the Cyclone after a 1st year period.

If your use has been light use or you have had the Cyclone turned off for long periods in the first year lubrication can be performed in the second year.

Inspection before / during your Maintenance.

1. Do an overall check of the entire Cyclone looking for any obvious defects or problems such as loose or broken parts. Any broken parts must be replaced with Cyclone parts.

2. Check all bolts and nuts and tighten any ones that are loose, re-apply “lock-tite” as directed on the “lock-tite” label. Replace any failed bolts and nuts with Cyclone bolts and nuts to retain your warranty. Using non-approved parts or bolts and nuts voids your warranty.

Lubrication:

Lubrication is grease, we are using an all weather white grease, lithium based or an composite grease are good, the main function is to keep all lubricated parts moving freely in all temperature and weather conditions.

Most greasing shown below in the pictures is added by hand.

The greasing of the generator bearings is done by grease gun. It is advised that you try your grease gun in advance on other items that need grease to make sure it is operating properly. Once you have confirmed you are getting a full output from the grease gun, attach the grease gun to the grease fitting.

Open and squeeze in one full prime of grease. This is all that is needed.

DO NOT over grease this will cause many problems to your Cyclone generator.



Models 800w-4.8kw This front bearing grease fitting is accessible with the body cover on. It is the same location on all models.



Models 800w-4.8kw Remove the Cyclone from the tower every 1-2 years and lightly apply grease by hand to the tower stub and bushings



Models 800w-4.8kw Remove tail fin from the tail fin mount every 1-2 years and lightly apply grease by hand to the tail fin mount and bushings. **DO NOT** over grease this area.

Trouble shooting		
Symptom	Cause	Solution
Blades are not turning	1.No wind 2.Blades are on backwards	1.Wait for wind 2. Reverse the blades
No volts are measured from all 3 output lines	1.Power output wire is not installed correctly or is broken. 2.Wire is damaged.	1.Check all connections. 2.Replace wire.
Volts are measured from only 1 or 2 output lines	1.Poor connections of output wires 2.Output wire is broken	1.Re-check all connections correct any bad connections. 2.Replace output wire
Power (amps) output is very low on all output lines from the wind generator	1.Windmill blades are turning slow–low wind 2.Poor connections.	1.Wait for higher winds 2.Check connections 3.
Power (amps) output is very low on 1 or 2 output lines from the wind generator	1.Broken or exposed wires 2.Exposed or broken connections	1.Use multi-meter and measure all 3-output lines from wind generator. The Ohms should be the same on all 3 output wires if the Ohms is much higher on 1 or 2 lines then the lines with high output are grounding out at some point between the wind generator and your test location – find, repair or replace the faulty wires.
Cyclone shakes when blades are turning	1.Improper balance of the blades and hub.	1.Check if the distance is equal between all blades. If the problem continues: 2.Balance blades and hub - contact dealer.
Cyclone shakes only when producing power.	1.Batteries too small. 2.No batteries-grid tie controller fights other components. 3.Dump load too small	1.Make sure your battery bank is large as suggested in the manual. 2.Stop Cyclone and consult professional for specific instructions. 3.Increase dump load
Thumping noises from generator.	1.Batteries too small. 2.No batteries-grid tie controller fights other components. 3.Dump load too small. 4.No grease in bearings.	1.Make sure your battery bank is large as suggested in the manual. 2.Consult professional. 3.Increase dump load 4.Add grease to grease fitting
Squealing noise from generator.	1.Bearings need grease if it has been in operation for more than 1 year. 2.	1. Add grease – consult manual for lubrication.

Frequently Asked Questions:	
Question:	Answer:
1. Can I operate the Cyclone without batteries to heat water with an electric heating element?	1. No, this practise besides that it does not work, will void your warranty.
2. Can I attach 2 Cyclone's together at the same time and wire them into 1 controller?	2. Cyclones are 3 phase AC. We do not offer any components that would be needed to synchronize 2 sources of AC power inputs.
3. Can I use my controller without a dump load attached to it?	3. No the dump load is designed as a safety feature to make sure that batteries are not over-charged and also to make sure the Cyclone never becomes run-away with no control. If it does become run-away it will self-destruct.
4. Can I make changes to my Cyclone, such as add longer blades, etc?	4. No any changes will void your warranty.
5. I live in a town or city can I use a Cyclone wind generator?	5. It is advised to contact any authority that would oversee any installations of this type such as building inspector or hydro utility authority. They can give you this answer.
6. Can I mount my Cyclone on a house or a building?	6. The main problem with this practice is that in medium high-to-high winds the house / building becomes a "speaker" similar to one on a radio. No matter what mounting material is used to absorb the frequency created by high outputs of the wind generator there are always noises present in the home or building. Also the next concern is that the Cyclone may be too low and close to any objects that would cause air turbulence causing pre-mature wear and failure.
7. Can I leave the Cyclone operating at my cottage over the winter; we will be back in the spring?	7. No this is dangerous as this is a machine. Never leave it operating for long periods unattended.
8. Can I mount the Cyclone on any tower or TV antennae tower?	8. All Cyclones are much heavier then other wind generators in the same output class. There are no models that could be used on a TV tower. It is best to make sure the tower you purchase and use can support the weight and lateral force that the Cyclone will have when operating.
9. Can I use my own favourite brand of controller with the Cyclone?	9. Possibly. First it must be 3 phase AC input DC output and also the same voltage as the Cyclone you purchase. It should be 2X the rated output of the Cyclone. It MUST have a working dump load that is 2X the size of the controller. CONTACT us to be sure.

Warranty



Cyclone Wind Generator

Each unit is covered by a 5 year, “nose to tail” parts replacement warranty. If any part fails naturally by way of defect in materials or as a result of poor workmanship in production, while being used as proscribed by the manufacturer and installed in accordance to the instructions in this manual in the first 5 years of ownership from the date of purchase, we will replace the part for free.

To Qualify and Redeem Warranty:

Please fill in the warranty form in full attached to this installation and owners manual at time of purchase. You have one month to send in this warranty form from your purchase date receipt. We will look at all post-marked dates to confirm.

Keep your original bill of sale (proof of purchase).

Send the original warranty form and a “copy” of your bill of sale to the address located on the bottom of the warranty form (the bill of sale confirms many details of the sale terms when you made your purchase including the sale date).

Keep a “copy” of the warranty form for your own records including the shipping details of how you returned the warranty.

Please make sure when you send us the warranty form that it is a registered letter and requires a signature to be received by us.

Then both parties have an independent verified proof the warranty was sent and received by Cyclone.

Redeem:

Contact your Cyclone dealer with your proof of purchase and your warranty copy.

Your dealer / sales agent will provide you with a return warranty number. RWN#.

If it is deemed the part has failed prematurely, as in accordance to the warranty rules posted in this warranty agreement, we will provide you with the replacement parts for free.

Warranty Terms:

1. The warranty does not include any shipping or customs costs that may be incurred while returning the parts for replacement to the dealer or manufacturer.
2. The warranty does not include any cost incurred or inconvenience to the owner for the removal of the Cyclone wind generator from the tower.
3. The warranty does not include loss of service of your Cyclone while warranty is being performed.
4. The warranty does not include any costs incurred to the owner / purchaser for the dealer /installer /technician to find / locate any possible or confirmed defects.
5. This warranty is void in its entirety if it is found the Cyclone was installed using materials or methods not recommended by the manufacturer in the manual above.
6. This warranty is void in its entirety if it is found that the parts are damaged by means of abuse, accidental breakage or neglect of maintenance, which caused defects of materials or parts of the Cyclone.
7. This warranty is void in its entirety if any alterations are made to the Cyclone, or parts added that are not Cyclone factory parts, or if it is operated with parts missing.
8. This warranty does not include damage incurred by storms: “see warranty storms below”.
9. There is no implied warranty to include free upgrades or changes made to any existing model after you purchase.
10. This warranty does not include any damage by any type of lightning.
11. This warranty is void in its entirety if you knowingly install the Cyclone in an area that has extreme conditions such as blowing sand, ice storms, wind shears, tornados, hurricanes, large damaging hail etc. If you are located in such an area we will try to make special arrangements of a “limited site specific warranty” based on your extreme conditions. This warranty may not carry the same terms or conditions but failure to report these conditions could result in cancellation of your warranty and refusal to honour any and all warranty claims.
12. This warranty does not include any liable or legal suits for possible damage claim, claim to personal injury, claim to loss of life, claim to damage of property, loss of any type as the result of part failure, general operation, maintenance, or storm damage where any loss or injury is incurred by operation or installation of the Cyclone wind generator or its related parts.
13. This warranty does not cover any damage to the Cyclone or any type of implied liability if the damage is the result of tower failure. Tower failure can be attributed to many things including maintenance, guy wire failure, weather and soil conditions, cement conditions in the tower base and anchors. Tower failure can be caused by many external factors of which cannot be fully covered in this subsection of this warranty clause. Tower failure = no warranty.
14. This warranty is void in its entirety if the Cyclone is used without batteries for grid tie use without submitting to us a formal electrical plan. Description, brand name and serial numbers of all components used in the grid tie with no batteries. We retain the right to refuse any warranty if we deem the installation improper or that it will shorten the lifespan of the Cyclone. A written reply will be sent out to applicants for warranty approval or refusal who plan on using the Cyclone for grid tie without batteries. Failure to inform us of these details will result in automatic cancellation of your warranty.

Hqt eg'O clgwt g*or act of god: 'Ic kwst g'iq' rgt hqt o 'lsu' qdhi c v kpu'y j gt g' twej 'Ic kwst g'ku' t' u 't gumv' qhi Cevu' qhi P c wst g' *ip enf lpi 'ht g' hqf . 'get vj s weng. 'lsqt o . 'j wt t lecp g' qt 'qvj gt 'pewt crif kucugt + 'y ct. 'lpxcukp. 'bev' qhi hqt gli p' lppo lgu' j quhlsigu 'y j gvj gt 'y ct 'ku' f gen t gf 'qt 'p qv: 'ekshiy ct. 'tgdgnkq. 't gxqnwkq. 'lpwtt g v kq. 'b klsct { 'qt 'wmt r gf 'r qy gt 'qt 'eqphuec v kq. 'igt t qt ku' bev' kshigu 'be v kq p c iur v kq. 'i qxgt po gpv' p' p v kq. 'dmenci g. 'go deti q. 'fcdqwt 'f lru wv. 'lnt lng. 'hqemqw' qt 'lpvgt t w v kq' qt 'Ic kwst g' qh ggevt leks' } 'qt 'vgnr j qpg' lgt xleg. 'bpf 'p q' qvj gt 'Ret v' 'y kn j cxg' t' li j v' lq' lgt o lpc w' vj ku' Ci t ggo gpv' wpf gt 'E r vug' 3; ' *Vgt o lpc v kq + lq' twej 'ekt ewo ucpegt \$

The term “storm” is subject to many interpretations such as lightning, blowing sand, wind, rain, hurricanes, wind shears, tornados etc. We reserve the right to refuse any warranty claims on storm damage if we deem the damage is the result of EXTREME blowing sand, wind conditions, hail, ice or lightning. We will verify any storm damage claims with local weather offices if a claim is made following a publicized storm with damage warnings.

(More details of wind descriptions and warranty wind tolerances are on page 33 of this manual).

Photo Verification:

Providing you have sent in your warranty agreement form at time of purchase as required in order to be eligible for the Cyclone 5 year limited warranty.

In order to process any claim as legitimate.

A Cyclone dealer or warranty depot must verify the warranty claim.

This means they need to see the Cyclone on the tower and also remove the Cyclone from the tower so they are able to determine why the Cyclone failed. This is not covered by Cyclone warranty so some fees may apply. You are responsible for these fees.

What to do if your location is not close to any Cyclone dealer or a Cyclone official warranty depot:

We ask that photographs be taken while the Cyclone is still mounted on the tower when the part fails or a defect is suspected. (If the tower has failed – no warranty) We need to see the following pictures: If the photos are electronic they can be e-mailed to us directly or your dealer we ask the size be a minimum of 1067 x 800 pixels and at least 72dpi.

1.	Pictures of the tower and guy wires, these pictures must be taken with other pictures below.
2.	The blades in relation to the tower and guy wires if used on your tower model
3.	The position of the Cyclone on the tower, views of all sides, front, and back. And bottom
4.	With tower lowered and Cyclone still installed on tower pictures of all electrical connections.
5.	Pictures of blade and hub condition
6.	Pictures of tail arm and supports
7.	Many detailed Pictures of any obvious defects or failures.
8.	If the Cyclone is in pieces gather all pieces on a level clean surface so we can see the condition they are in position them in what would be there normal attached location.

This will help us through the discovery process to verify correct installation and discover why there was a failure and to determine if it is product related. This also helps us to prevent a similar failure in the future if it is product related.

We are sorry for any inconvenience that the strict nature of our warranty causes those who have legitimate warranty claims.

Due to fraudulent warranty claims and misuse and/or neglect of our products, we have to impliment these measures to protect the warranty of honest customers.

We believe this promotes safer and more responsible use of our product.

We reserve the right to refuse any claims made that are determined by us to not be a failure in materials or workmanship.

Cyclone Wind Generator

Warranty Agreement Form

Please Print

Name of Purchaser /Owner:	
Purchaser / Owners Address:	
Purchaser / Owners Phone Number:	
E-Mail Address: optional	
Product Purchased From: Name and Address:	
Product Model Purchased:	
Generator Serial Number:	
Body Serial Number:	
Blades Serial Number:	
Date Purchased:	
Date Installed:	
Installed by:	
Controller brand name and serial No.:	
Intended Use - Please Choose by checking the box beside one of the following uses below:	
Battery Charging <input type="checkbox"/>	Water Heating <input type="checkbox"/>
Grid Tie <input type="checkbox"/>	
Other – Please Explain:	
Complete the form below if you are planning to grid tie or live in extreme conditions.	
Inverter Brand and Serial No: Grid tie no-battery use only:	
Voltage Clamp brand and serial No: Grid tie no-battery use only:	
Location Extreme Conditions: Explain:	

By signing below you swear you have read all operational rules and safety requirements for the operation of a Cyclone wind generator. You now know the potential risk to all persons in the public and to public/private property surrounding your installation. You agree and swear that all requirements have been met in order to qualify for warranty under our warranty agreements contract, and that your Cyclone or related products are installed according to our installation standards /instructions. You are confirming you have disclosed all details such as extreme conditions and grid tie use.

Purchaser / Owners Signature: _____

Dated: _____

Please return this form by registered mail requiring a signature receipt to the following address below. Attach a photocopy of your Bill of sale from the agent or dealer that you purchased the Cyclone Wind Generator and / or other Cyclone related products from.

Cyclone Green Power Inc. – Dept. Cyclone Warranty

1420 Dolly Varden Way,
Qualicum Beach, British Columbia
Canada V9K2V1
Phone: 1-250-738-0309